

SLIDE RAIL SPECIAL SOLUTIONS PIT SHORING

- ▶ By combining the corner rails with rolling strut frames, you can implement the widest range of pit dimensions.
- ▶ Strut-free trenches, for example for laying longer pipes, building a structure or for using a pipe jacking machine, can be realized with the clamping device.
- ▶ If the trench is deeper than the base rail length, you must extend it using extension rails.

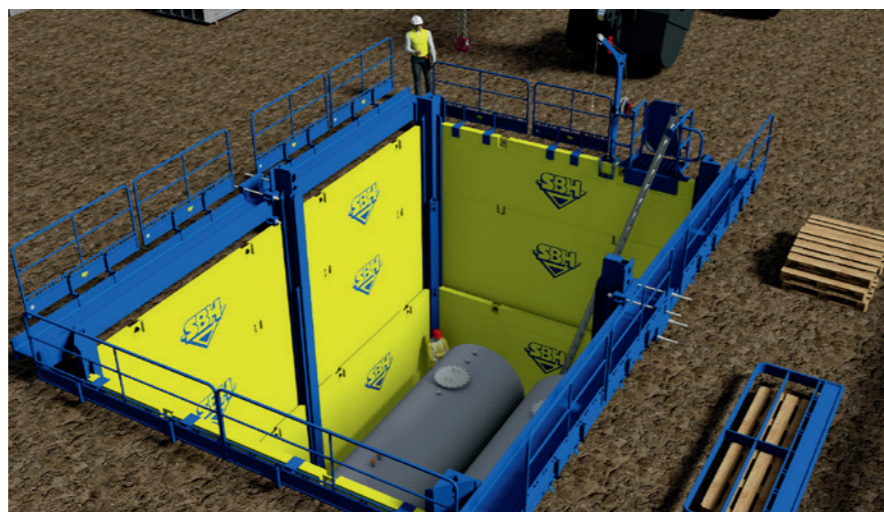
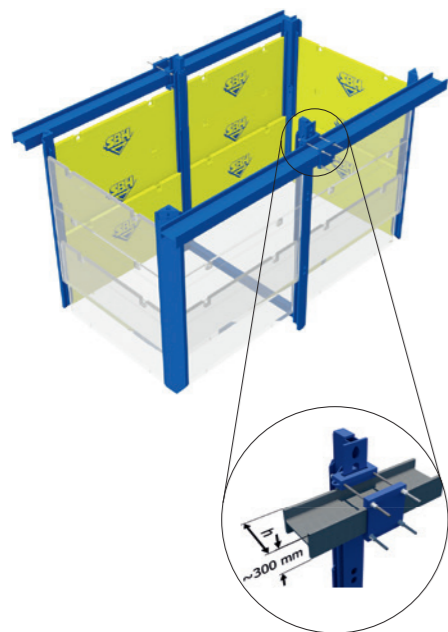
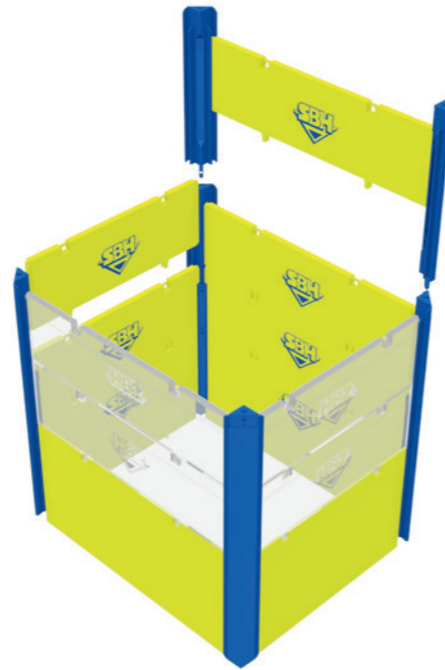

TECHNICAL PARAMETERS

Description	Dimensions [mm]	Weight [kg]
Clamping device for walers Width ~300.00 mm, height variable	550.00 x 520.00 x h	275.0

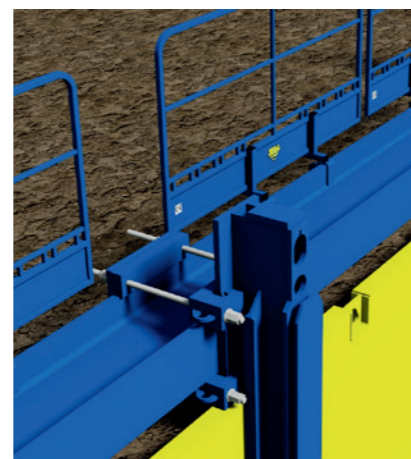
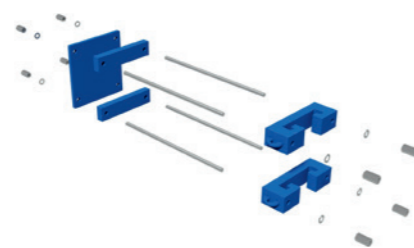

4-SIDED CORNER SLIDE RAIL

- ▶ The 4-sided corner slide rail is predominantly used for soil replacement works. Primarily for trench depths up to 3.80 m.

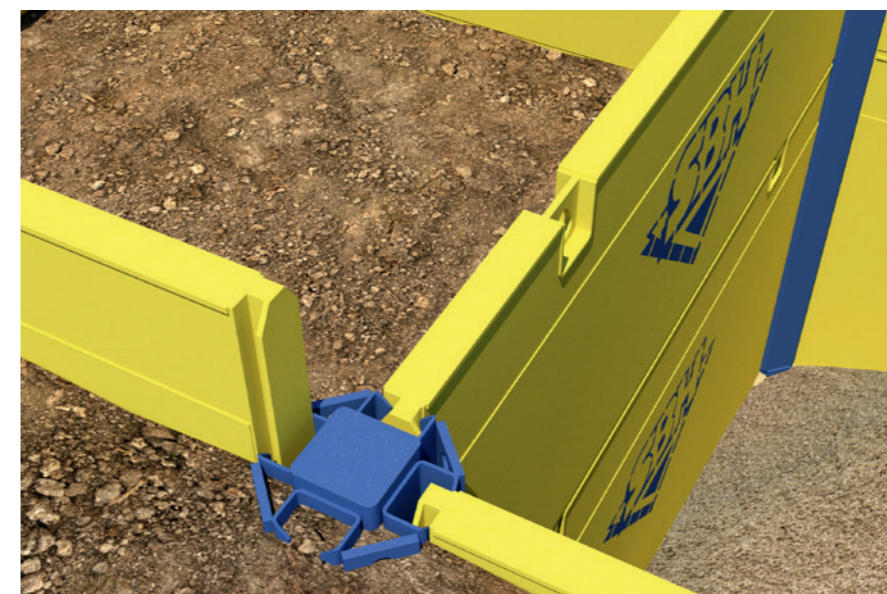

TECHNICAL PARAMETERS

Description	Rail length [mm]	Weight [kg]
4-sided corner slide rail	3500.00	780.0
	4000.00	880.0

SLIDE RAIL SPECIAL SOLUTIONS PILE CHAMBER SHORING



The pile chamber plates, with their guides at the sides, are also used in the rolling strut shoring. Where pipes and cables cross the excavated area, there are two options for using pile chamber plates.

- ▶ **Pile chamber with rolling strut shoring and walers**
The pile chamber plates inserted into the slide rails' outer guides, and so it is level with the ground surface. Depending on static requirements, one or more walers are inserted into the slide rail's inner guides further down.
- ▶ **Pile chamber with rolling strut shoring and slide rail plates**
The pile chamber plate is installed in combination with slide rail plates, whereby the slide rail plates are inserted into the slide rail's outer guides and the pile chamber plates are inserted further down, in the slide rail's inner guides.
- ▶ The corner connector provides a friction-locked connection between the pile chamber plate, to form a pit shoring.

PILE CHAMBER PLATES $h = 1.00\text{ m}$

Plate length L_{PCE} L with guide [m]		Pipe clearance length L_C im PCE [m]	Number of KD 6/8	Inner plate thickness t_{PI} [mm]	Permitted boom bracing load q [kN/m]	Weight per plate without/with guide [kg]
1.90	2.00	1.62	3		261.2	470.0 / 505.0
2.34	2.44	2.06	4		171.6	560.0 / 595.0
2.84	2.94	2.56	5	120.00	116.6	660.0 / 695.0
3.42	3.52	3.14	6		80.4	775.0 / 810.0
3.92	4.02	3.64	7		61.2	875.0 / 910.0
4.42	4.52	4.14	7		116.8	1325.0 / 1360.0
4.92	5.02	4.64	8	170.00	94.3	1470.0 / 1505.0
5.42	5.52	5.14	9		77.7	1605.0 / 1640.0
5.92	6.02	5.64	10		65.2	1750.0 / 1785.0

Other lengths or custom variants upon request.

